

# ELECTRICITY

From Flowing Charges to Modern Power.

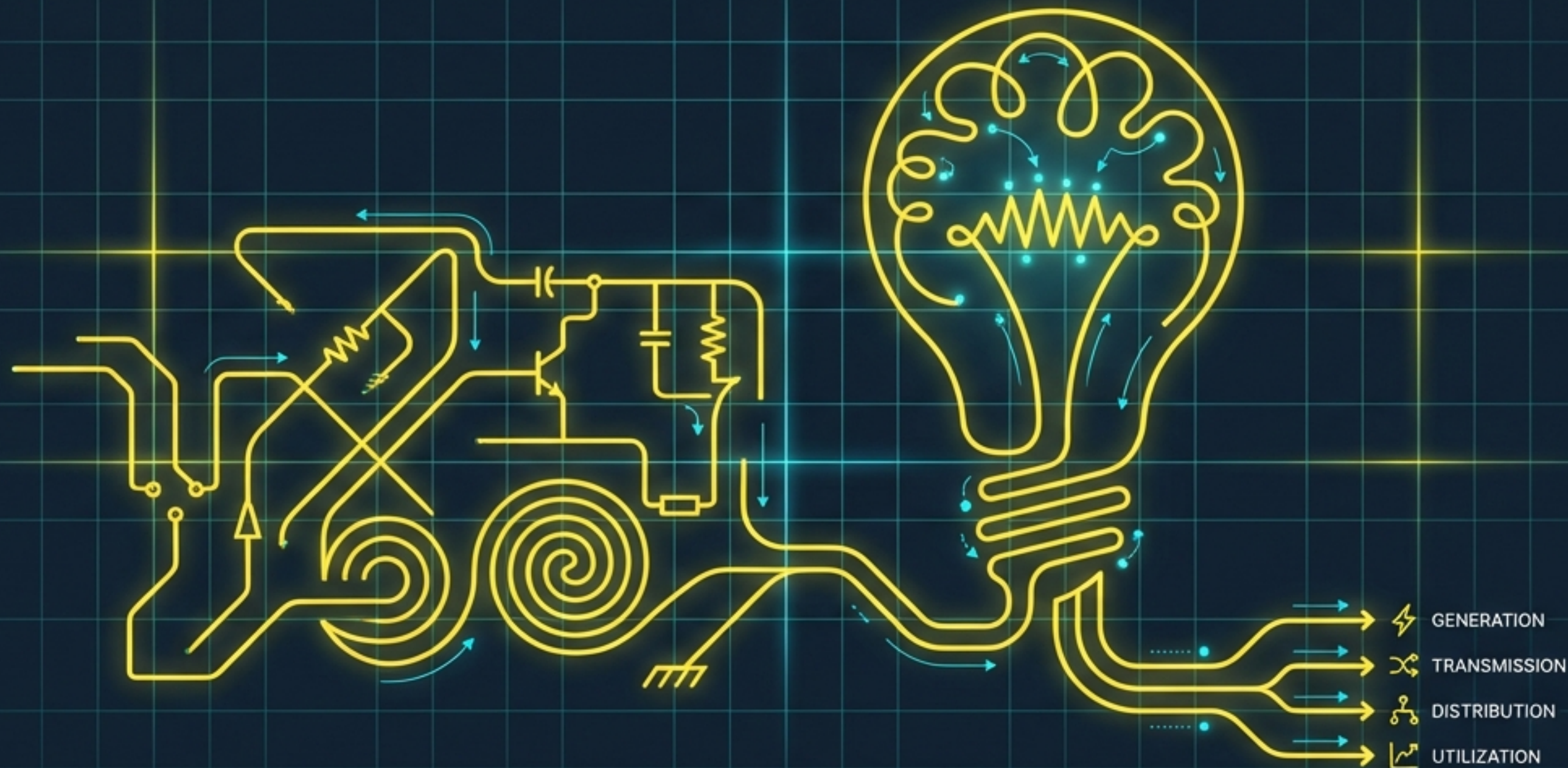

# WATER CURRENT

Flow of Water Molecules

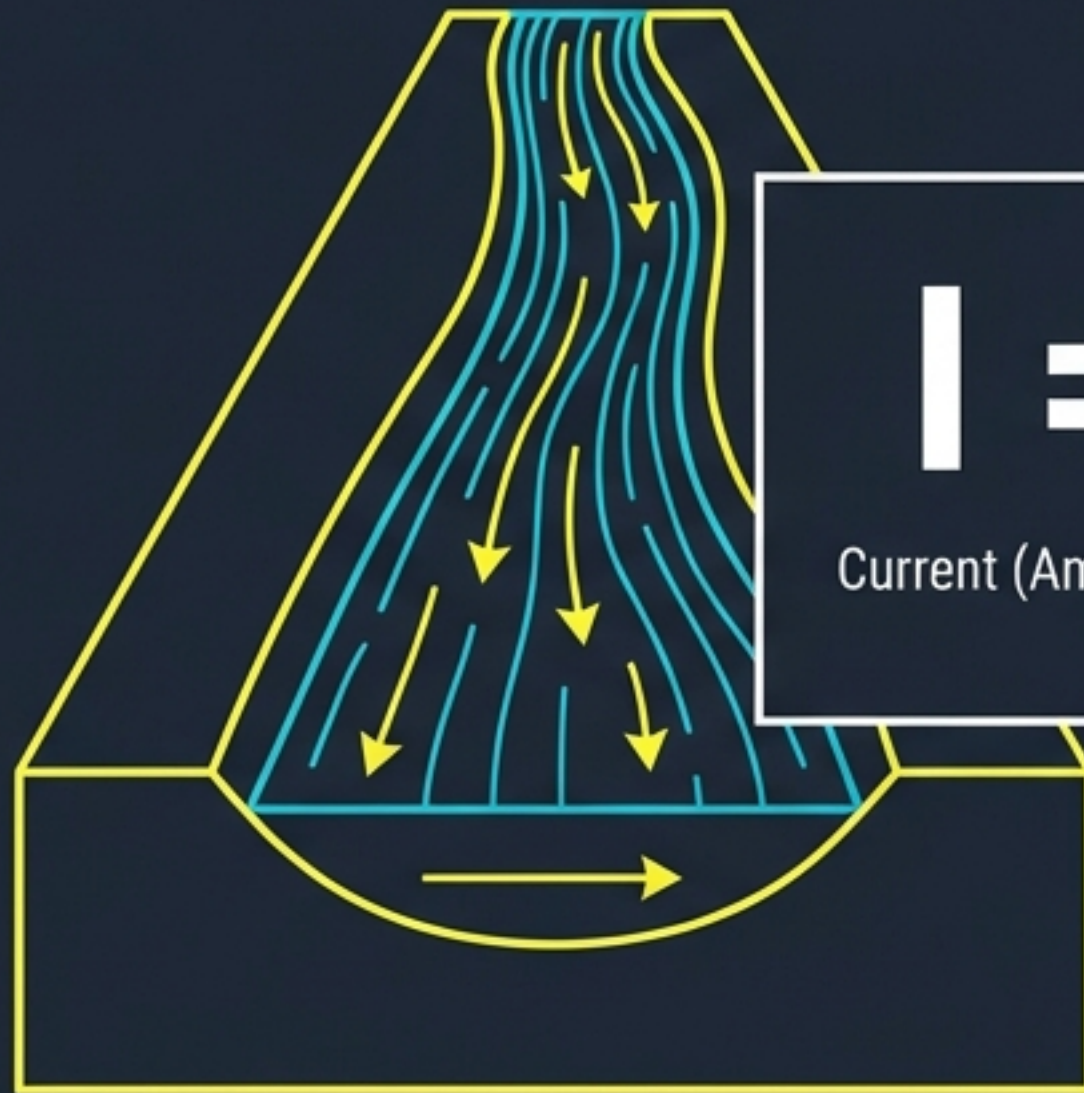

# ELECTRIC CURRENT

Flow of Electrons

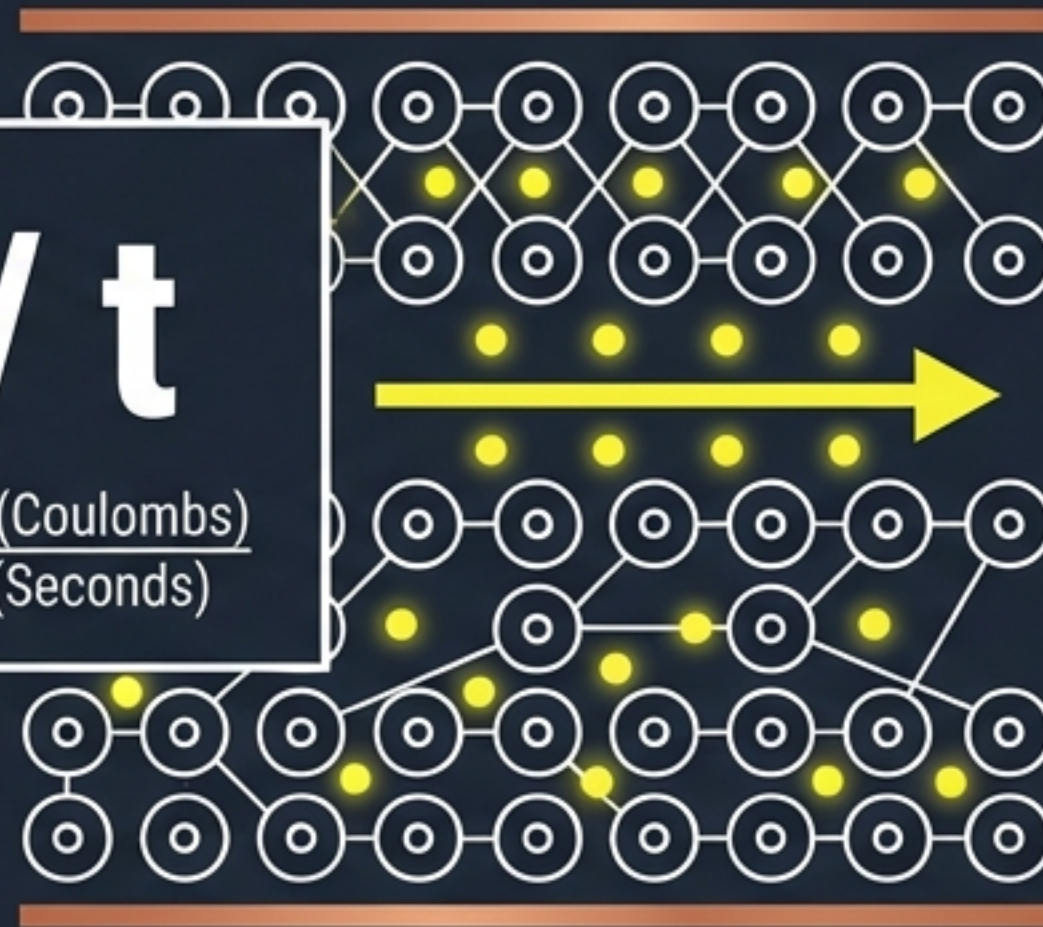

$$I = Q / t$$

Current (Amperes) =  $\frac{\text{Charge (Coulombs)}}{\text{Time (Seconds)}}$

## THE FLOW PARADOX

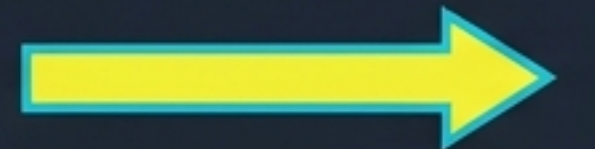

Conventional Current (+ to -)

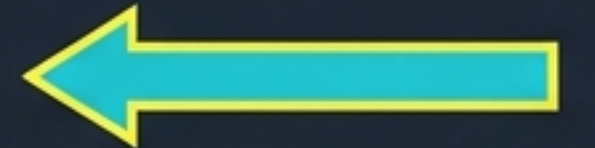

Electron Flow (- to +)

We map the flow of positive charge, even though electrons do the moving.

# POTENTIAL DIFFERENCE

The Driving Force of Electricity

No Pressure Difference = No Flow



Water levels are equal;  
no net flow occurs.

Pressure Difference = Flow

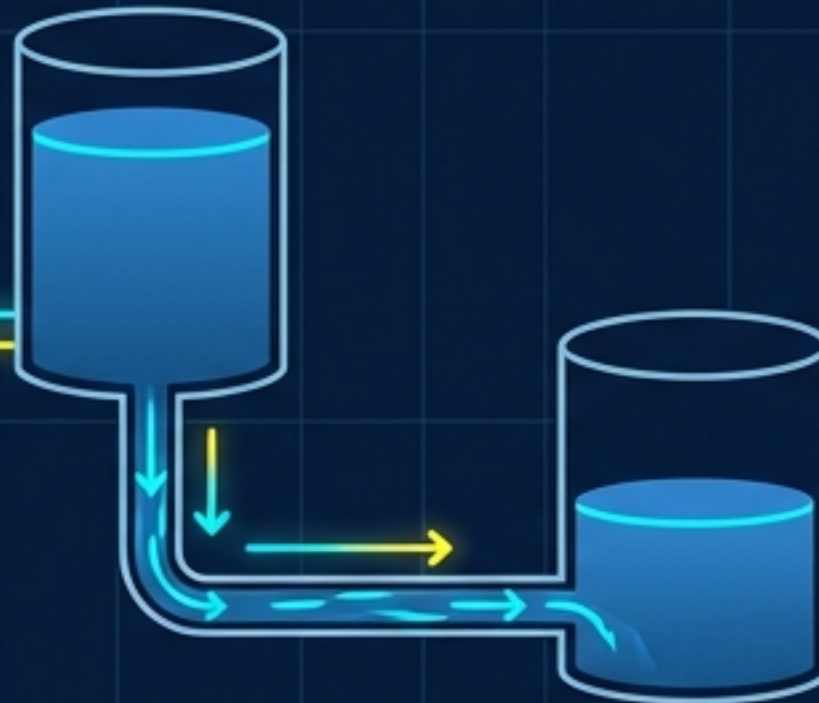

Gravity creates pressure difference,  
causing rapid water flow.

Voltage = Electric Pressure

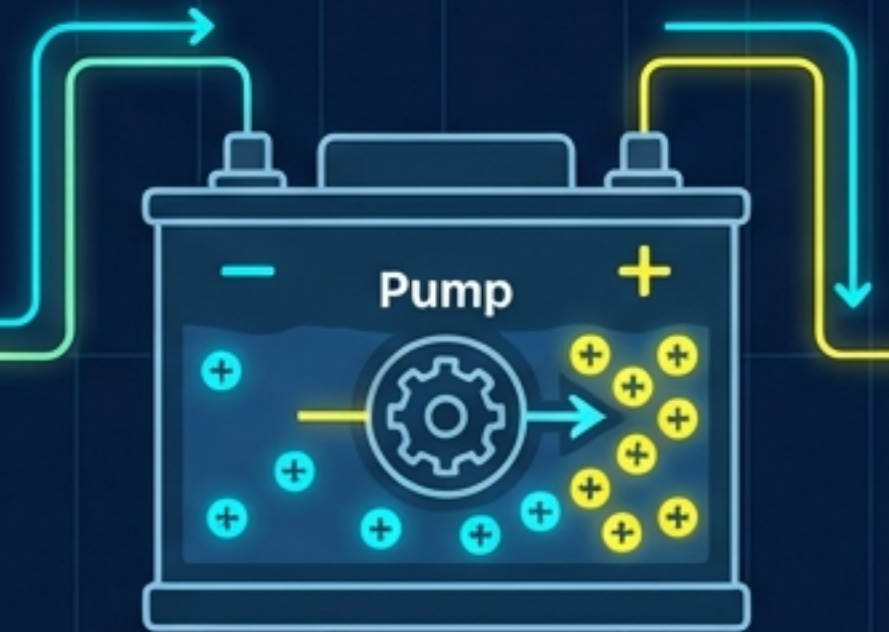







The battery (pump) creates electrical  
pressure, driving charge through the circuit.

$$V = W / Q$$

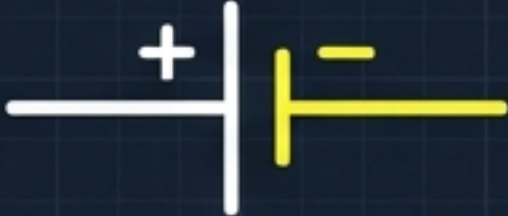
1 Volt = 1 Joule of work to move 1 Coulomb of charge.

# MAPPING THE PATH

From Reality to Schematic

Component	Symbol
	
	
	
	

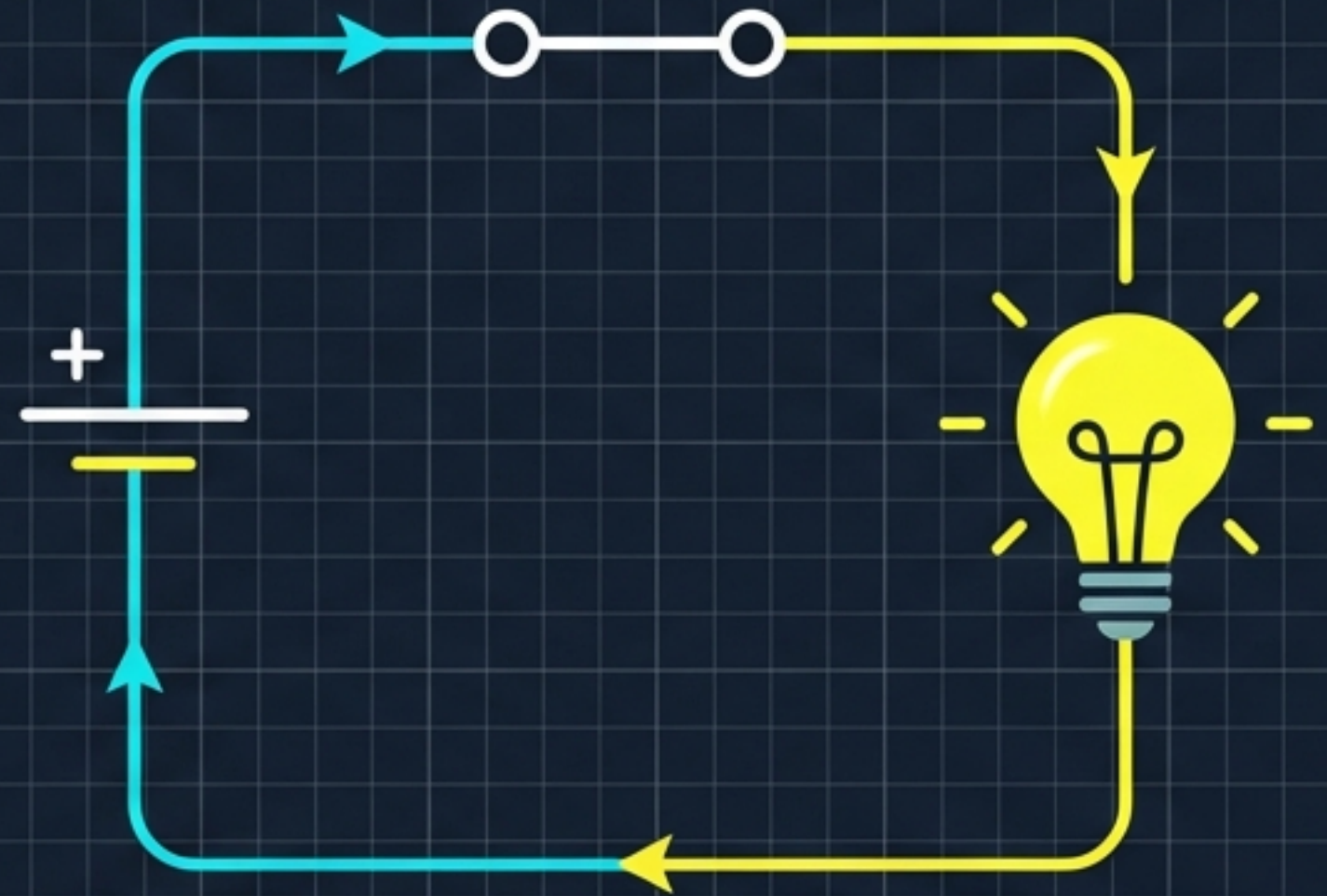

# OHM'S LAW

The Fundamental Rule

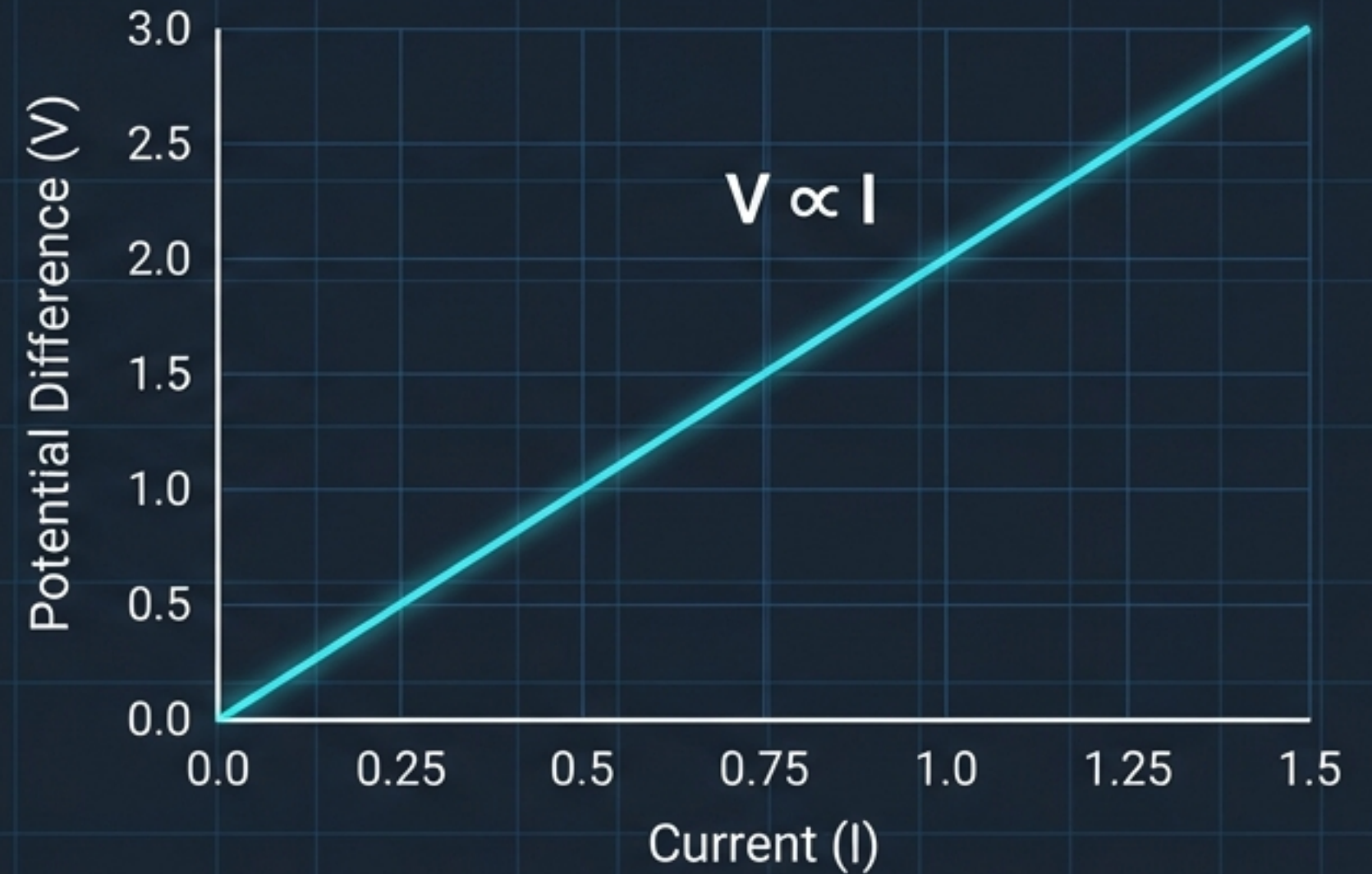
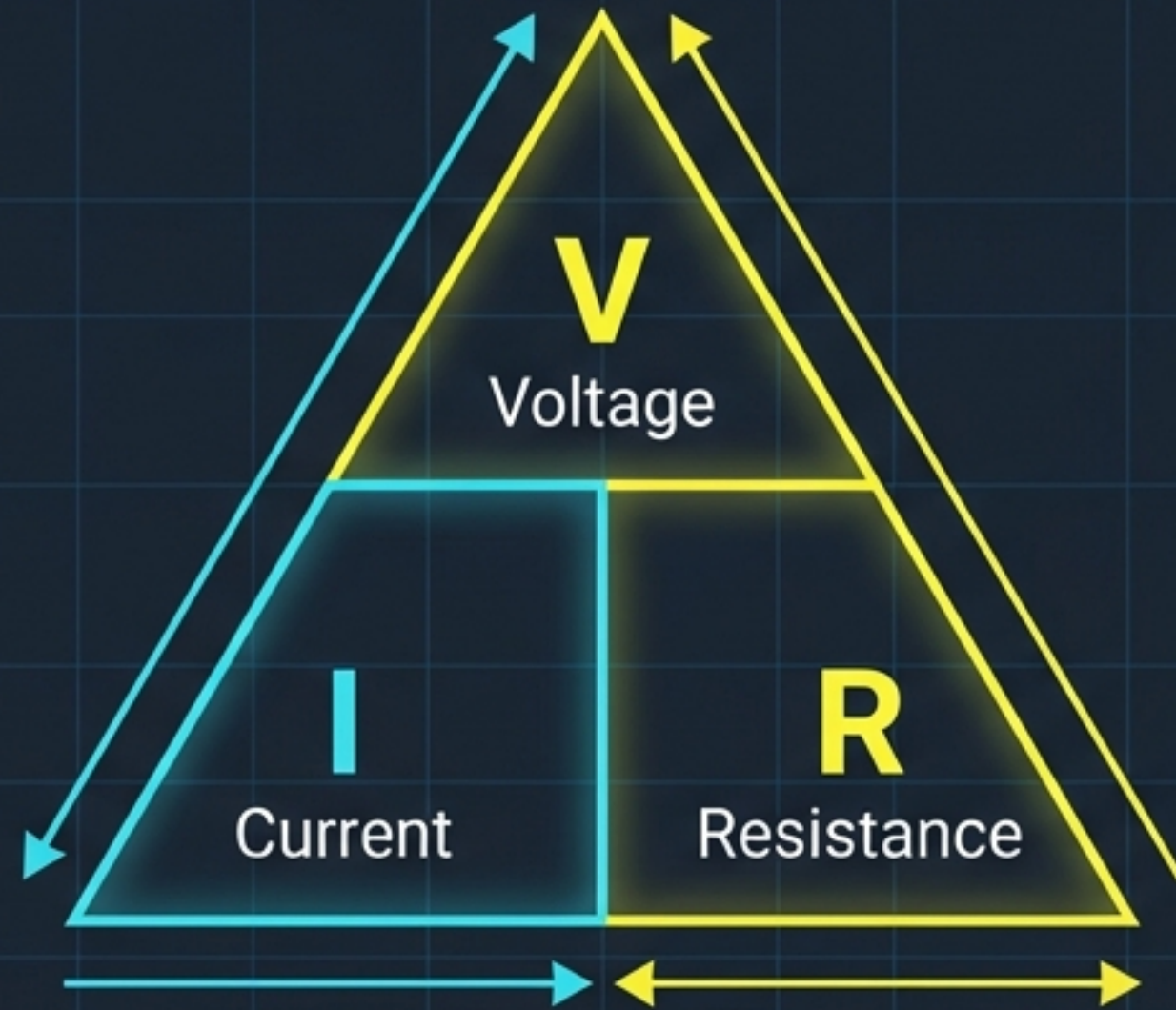

$$\text{Formula: } V = IR$$

Voltage pushes. Resistance fights. Current flows. Provided temperature remains constant, the current flowing through a conductor is directly proportional to the potential difference across its ends.

# RESISTANCE

The Opposition to Flow

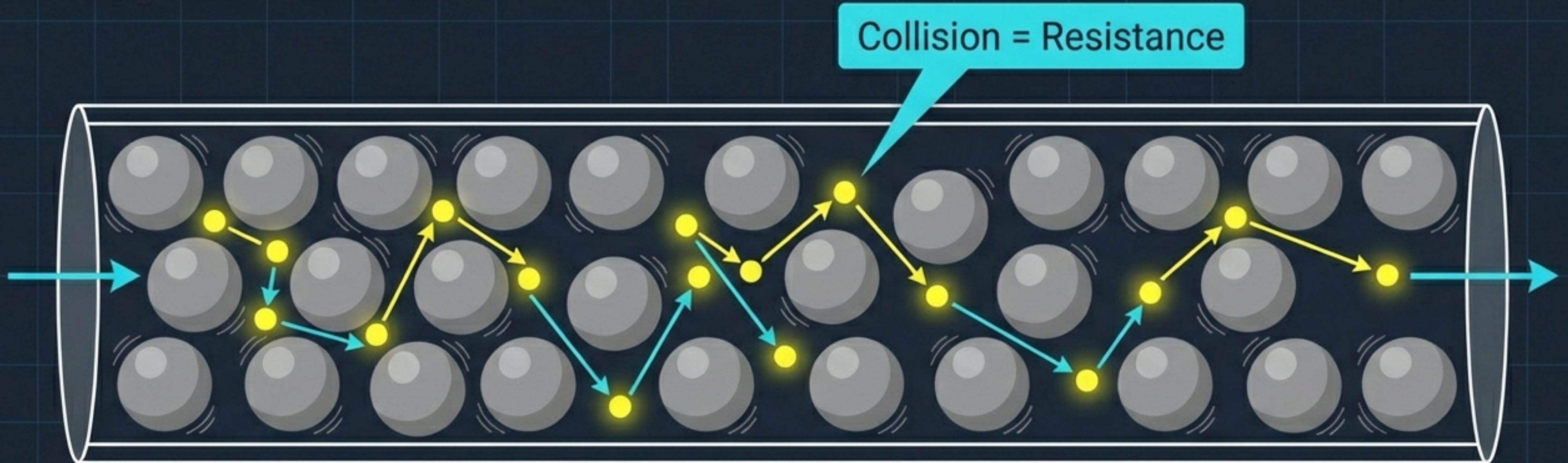

**Unit:**  
Ohm ( $\Omega$ )

**Definition:**  
 $1 \text{ Ohm} = 1 \text{ Volt} / 1 \text{ Ampere}$

**Variable Resistance:**  
A device (Rheostat) used to regulate current without changing the voltage source.

# FACTORS AFFECTING RESISTANCE

Comparison 1: Length (l)

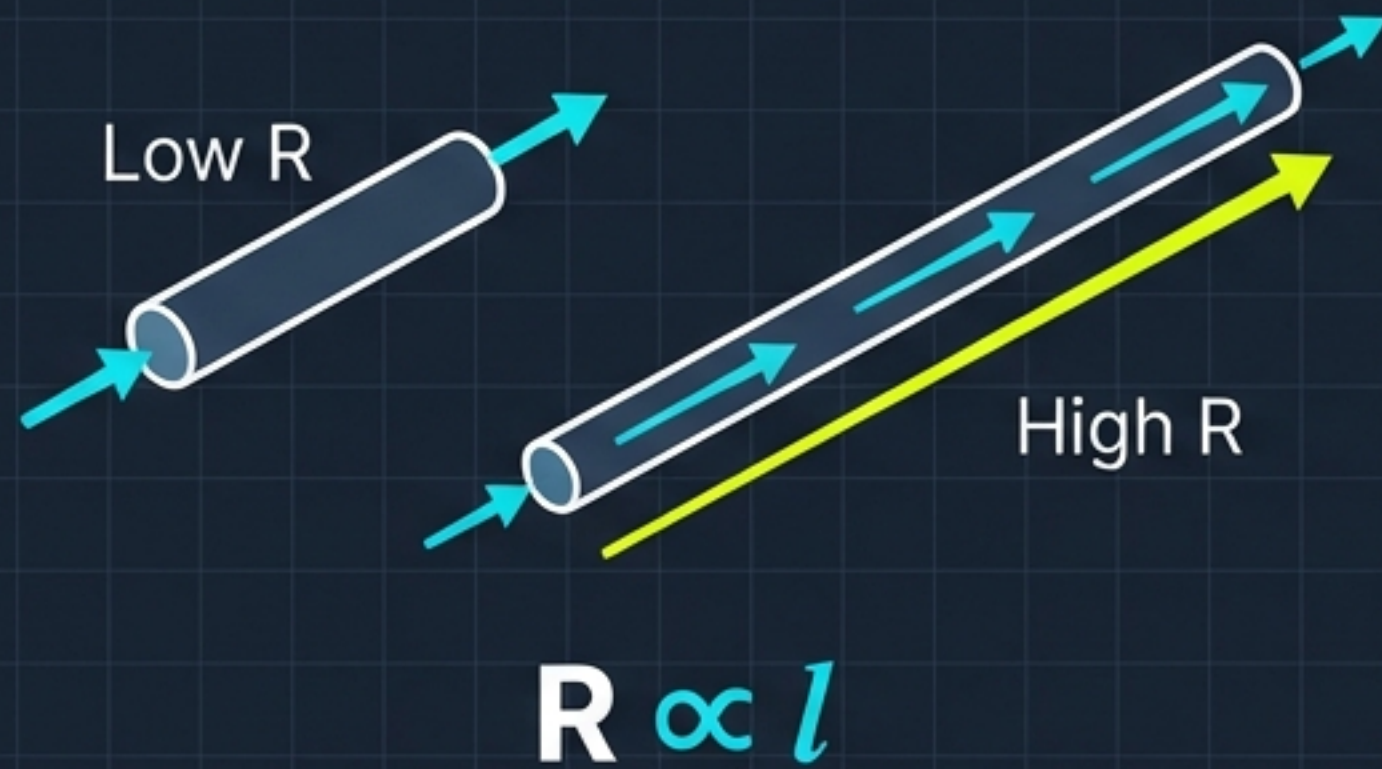

Comparison 2: Cross-Section Area (A)

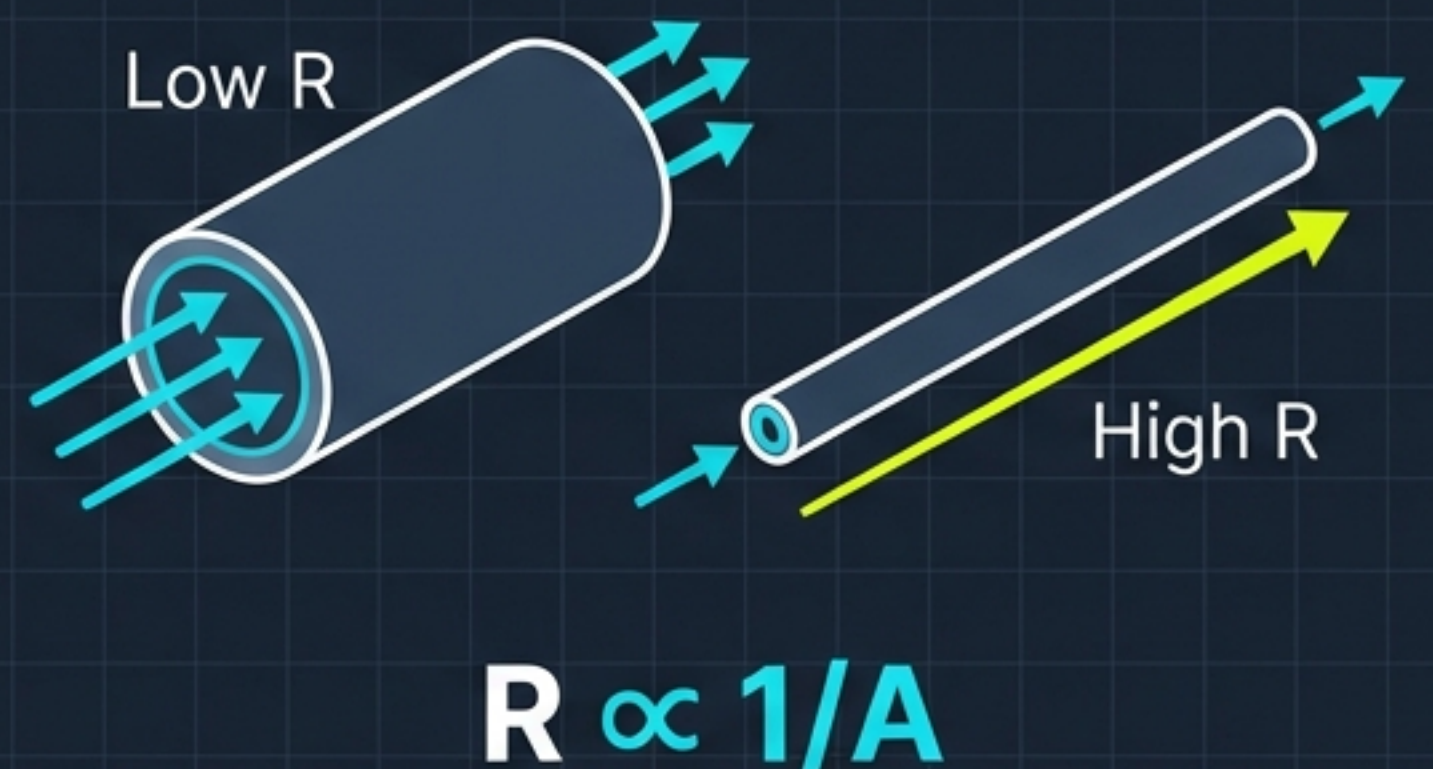

$$R = \rho (l / A)$$

Resistance depends on Length, Area, and Material (Resistivity  $\rho$ ).

# RESISTIVITY ( $\rho$ )

The Material Property

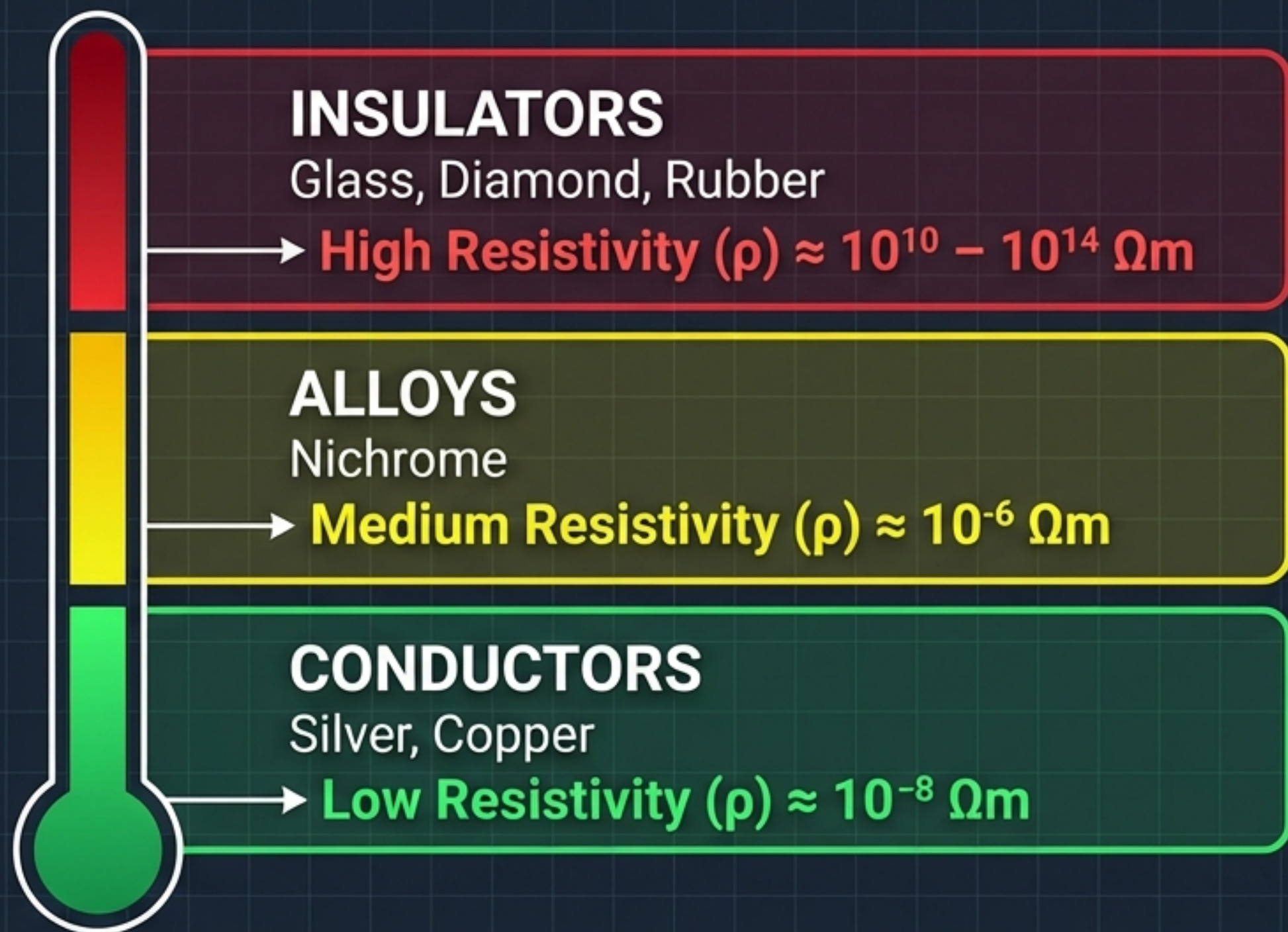

## WHY ALLOYS?

Alloys (like Nichrome) have higher resistivity than pure metals and do not oxidize at high heat. Ideally suited for toasters and irons.



# SERIES CIRCUITS

The Single Path

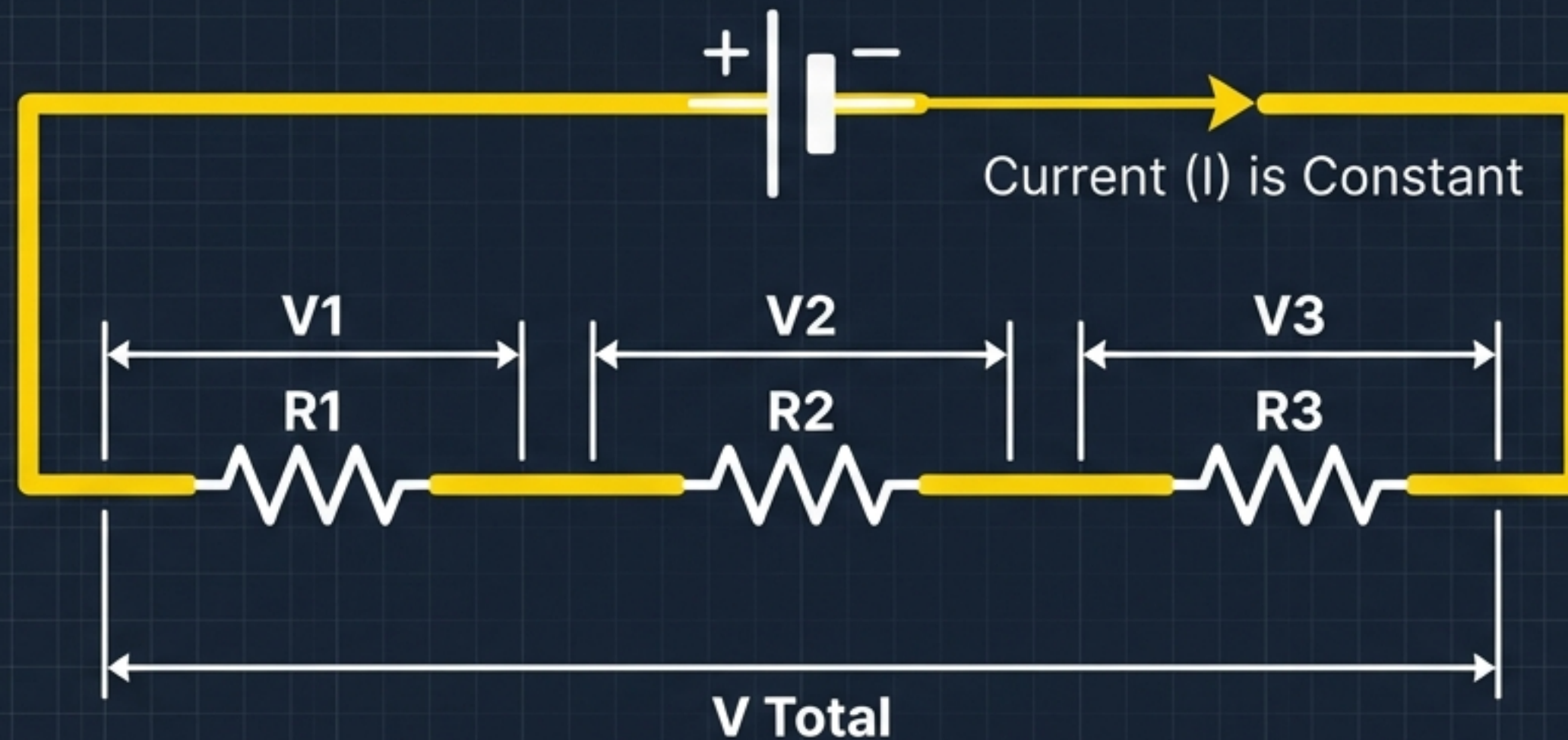

$$R_s = R_1 + R_2 + R_3$$



**System Failure:** If one component breaks, the entire circuit stops.

# PARALLEL CIRCUITS

The Split Path

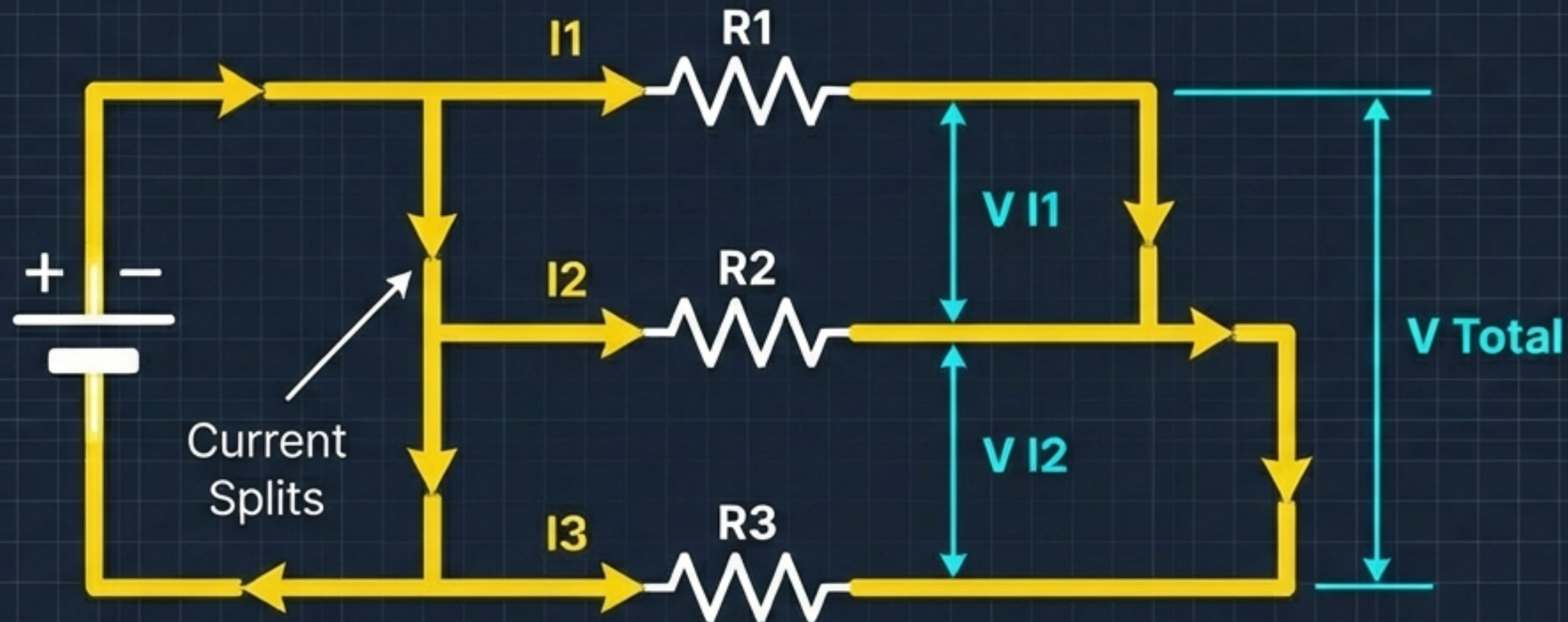





$$\frac{1}{R_p} = \frac{1}{R_1} + \frac{1}{R_2} + \frac{1}{R_3}$$



**System Resilience:** Components operate independently. Total resistance is lower.

# SERIES VS. PARALLEL

## System Comparison

<b>Series Circuit</b> 	<b>Parallel Circuit</b> 
<b>Same current</b> flows through all parts.	<b>Current divides</b> between branches.
<b>Voltage splits</b> across components.	<b>Voltage is same</b> across each component.
<b>Total R is greater</b> than highest resistor.	<b>Total R is less</b> than lowest resistor.
One fails, <b>all fail.</b> 	<b>Independent</b> operation. 

Parallel is the standard for domestic wiring.

# HEATING EFFECT

Joule's Law

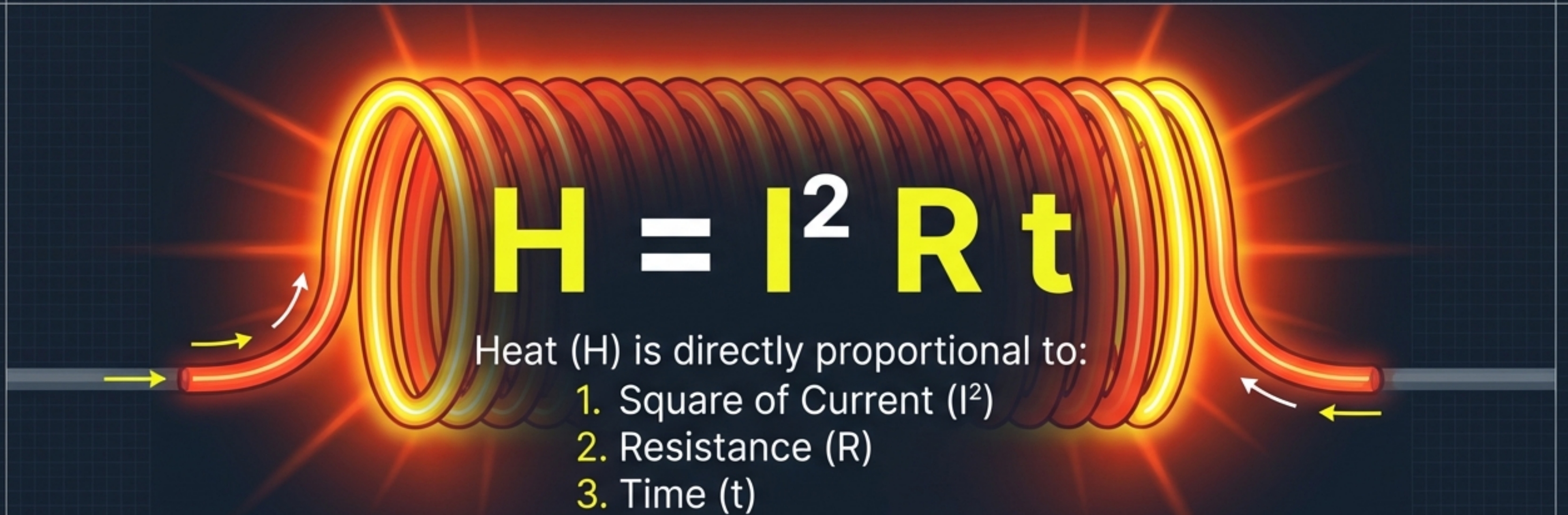

Energy Transformation: Electrical Energy  $\rightarrow$  Heat Energy.  
In a fan, this heat is waste. In a toaster, it is the goal.

# ENGINEERING APPLICATIONS

## The Bulb



### Tungsten.

High melting point ( $3380^{\circ}\text{C}$ ).  
Thermally isolated  
to emit light.

## The Heater



### Nichrome.

High resistance alloy.  
Doesn't oxidize at  
high temps.

## The Fuse



### Safety Device.

Wire with low melting point.  
If  $\text{Current} > \text{Rated Value}$ ,  
wire melts and breaks circuit.

# ELECTRIC POWER

$$P = VI$$

The rate at which electric energy is consumed.

Watt (W). 1 Watt = 1 Volt × 1 Ampere.

## Commercial Energy

The Unit (kWh)



**1 Kilowatt Hour =  $3.6 \times 10^6$  Joules**

“We do not pay for electrons; we pay for the energy to move them.”

# FORMULA SUMMARY

## THE FLOW

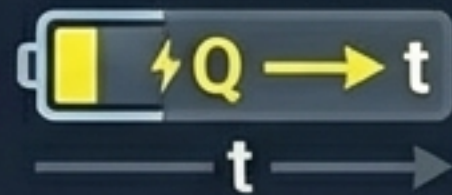
$$I = \frac{Q}{t}$$

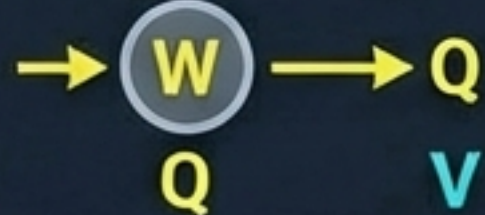
$$V = \frac{W}{Q}$$

## THE RULE

$$V = IR$$

(Ohm's Law)

$$R = \rho \left( \frac{\ell}{A} \right)$$

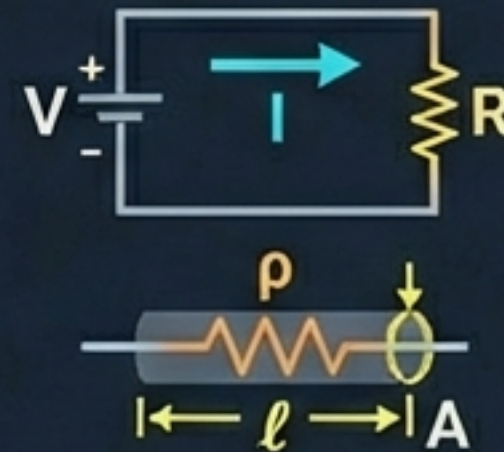

## THE SYSTEM

Series:  $R_s = R_1 + R_2 \dots$

Parallel:  $\frac{1}{R_p} = \frac{1}{R_1} + \frac{1}{R_2} \dots$

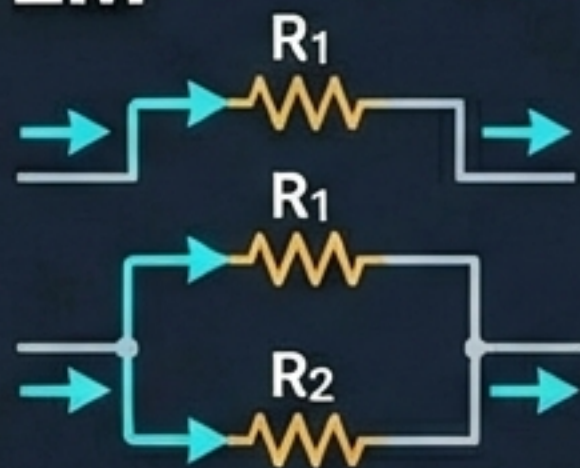

## THE OUTPUT



Power:  $P = VI$



Heat:  $H = I^2 R t$

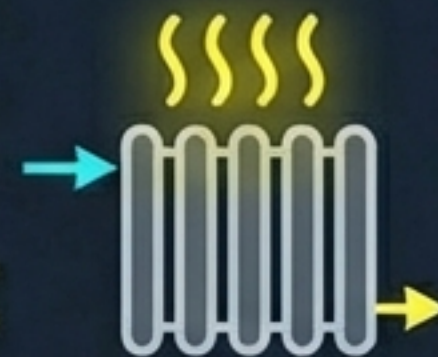

Electricity is energy under control.