

The Hidden Dance of Matter

Understanding Chemical Reactions and Equations

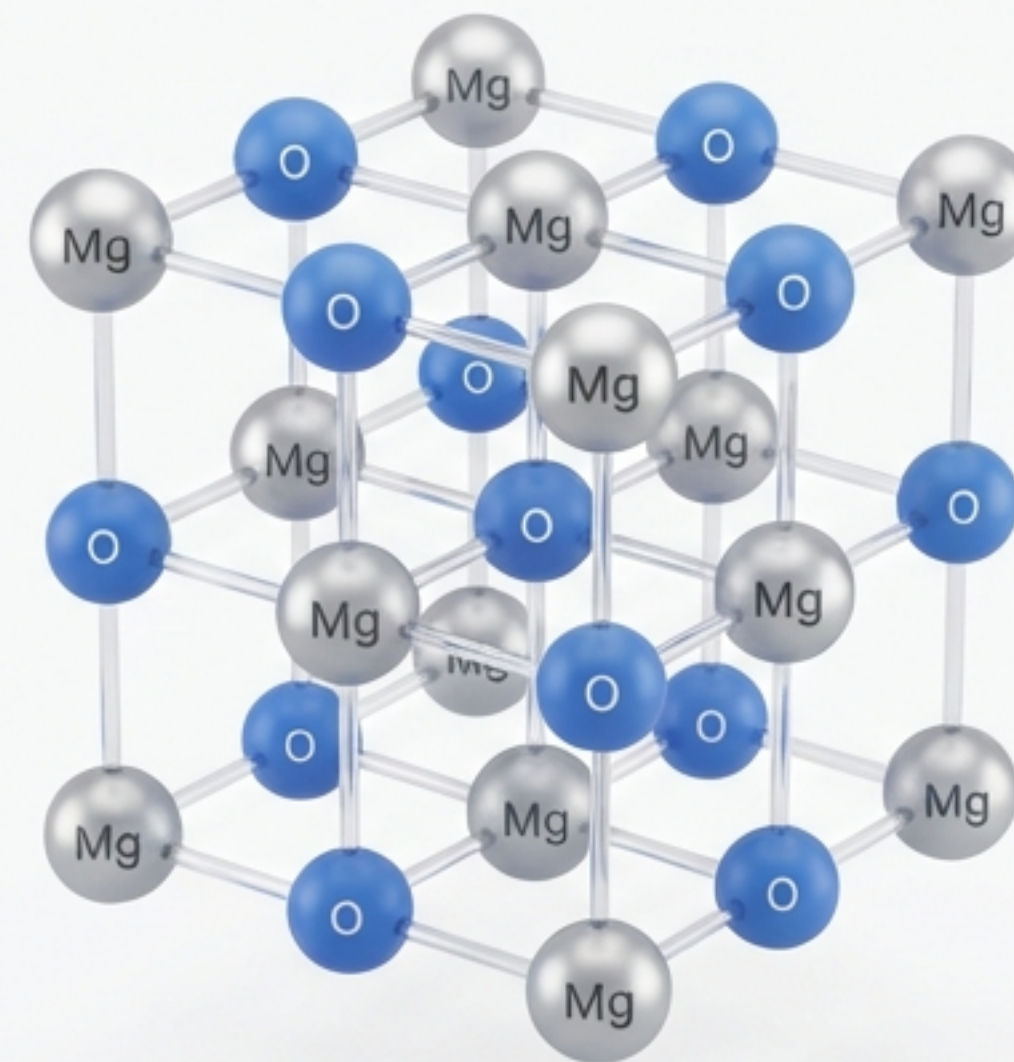

Whenever a chemical change occurs, we say a chemical reaction has taken place.
It is not magic; it is the rearrangement of atoms.

Change is the Only Constant

Distinguishing Chemical Identity from Physical State

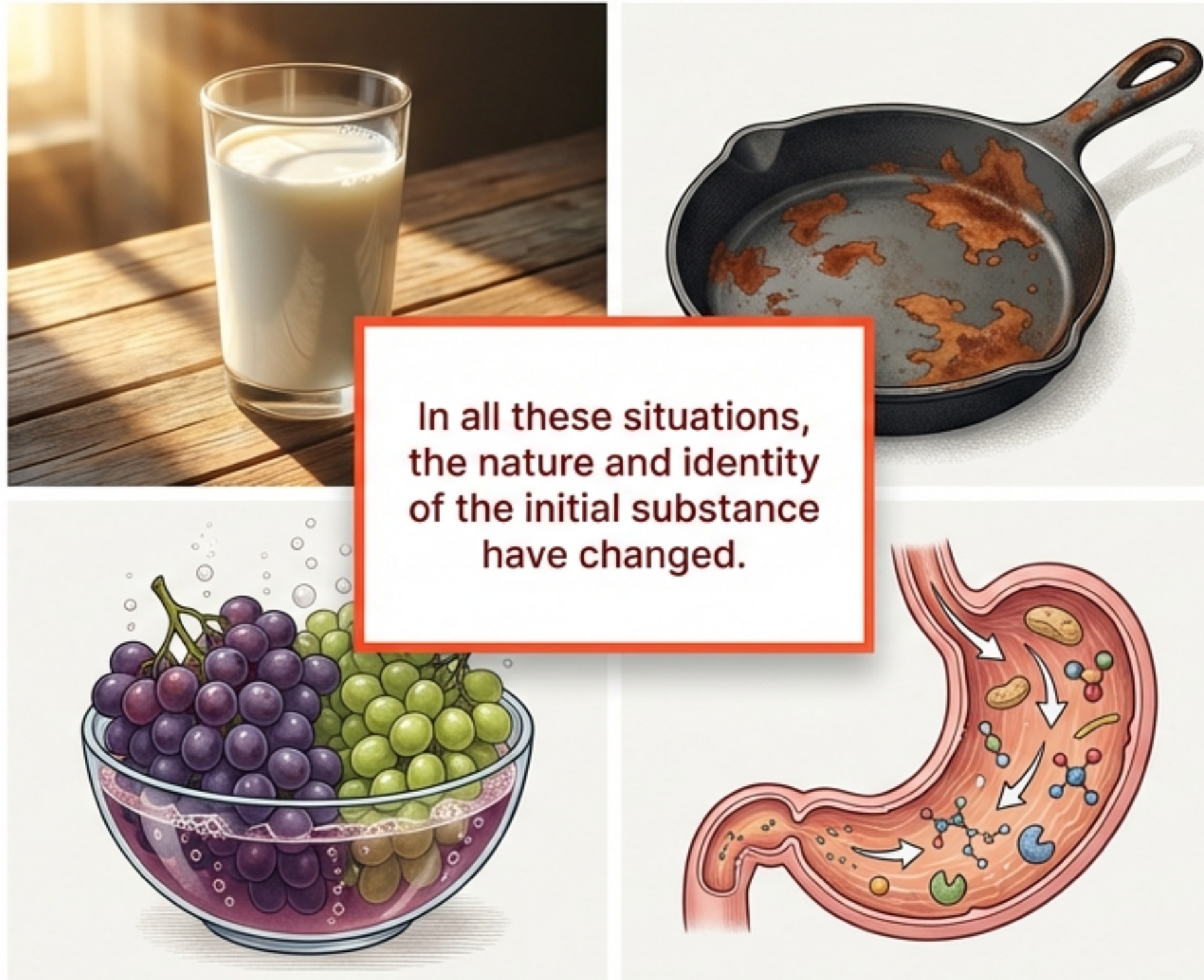

Physical Change
(Reversible)

The Fingerprints of a Reaction

Four Observable Indicators

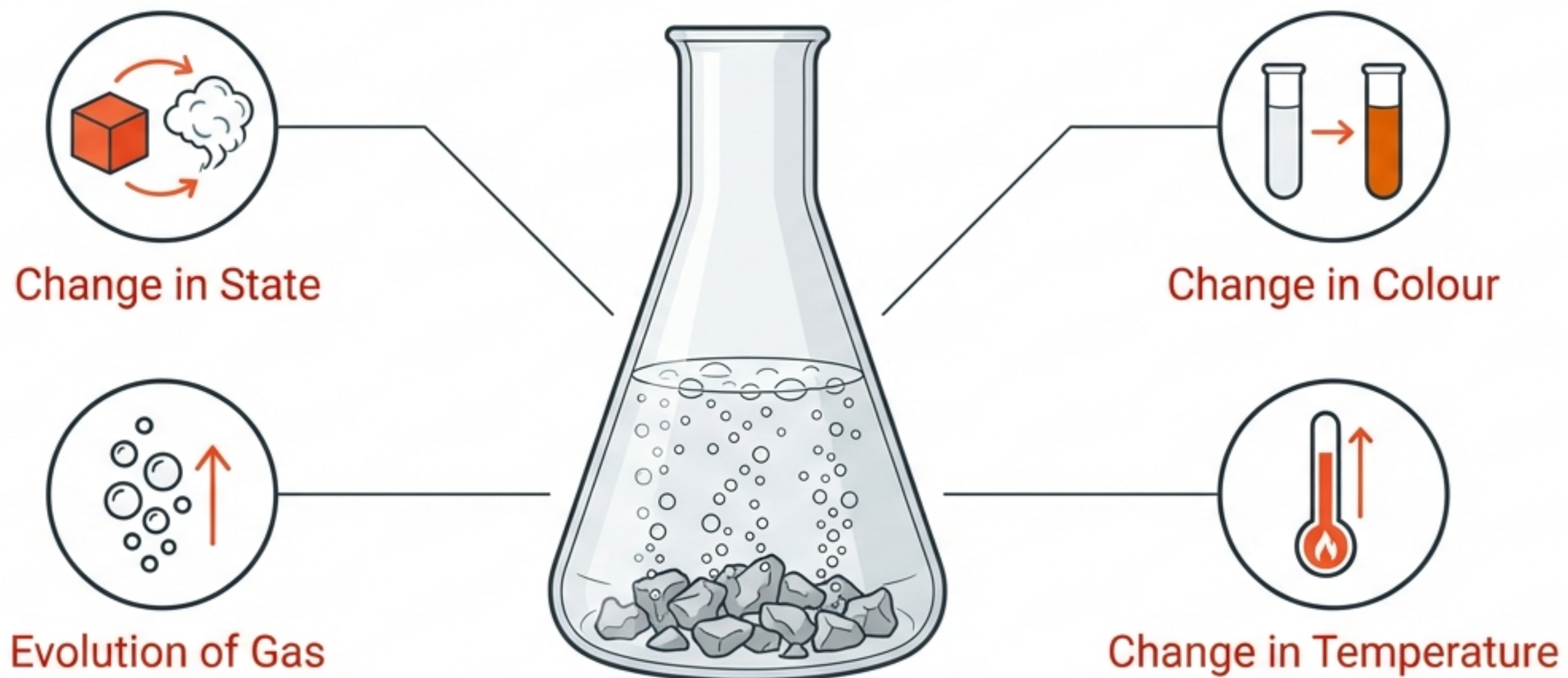

Touching the flask reveals a rise in temperature—evidence of energy release.

From Sentences to Symbols

The Sentence

Magnesium burns in oxygen to form magnesium oxide.



The Word Equation

Magnesium + Oxygen →
Magnesium oxide



Reactants
(LHS)



Products
(RHS)



The Skeletal Equation

Mg + O₂ → MgO

 | |
reacts with yields

The Law of Conservation of Mass

Matter is neither created nor destroyed.

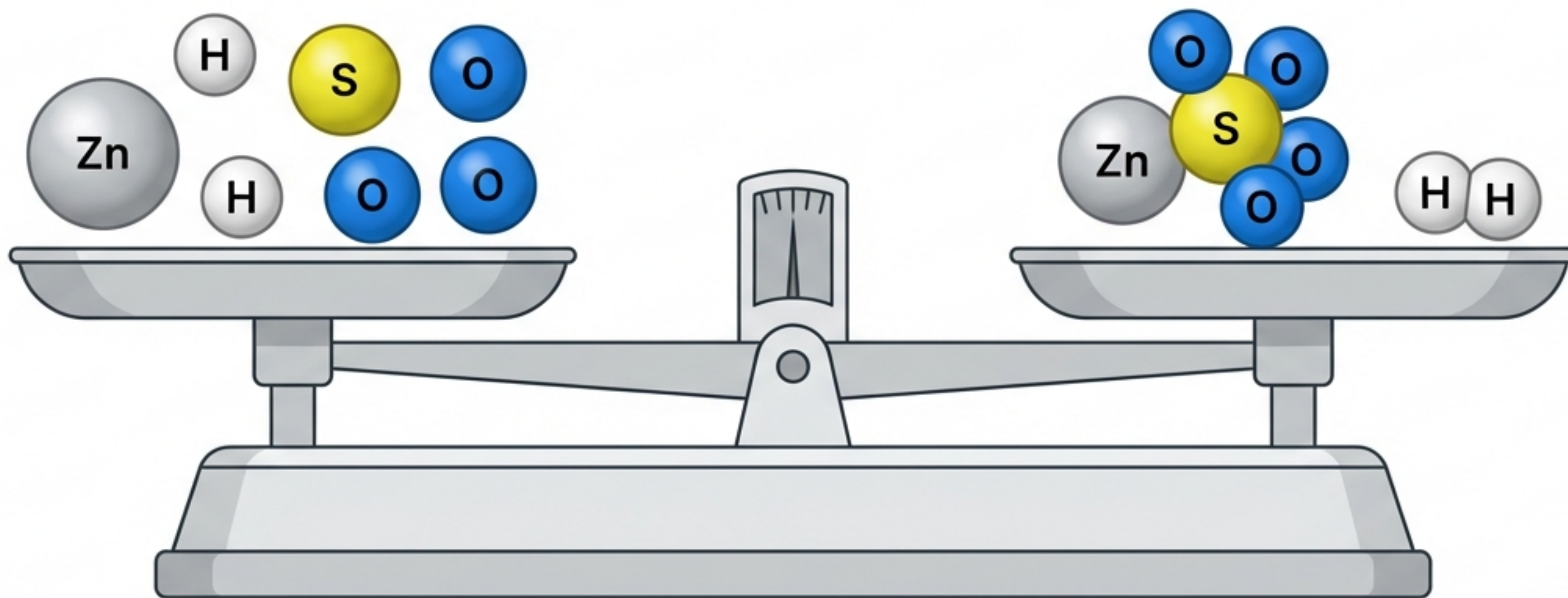

Total Mass of Reactants = Total Mass of Products

The number of atoms of each element remains the same before and after the reaction.

The Mechanism of Balancing

The Hit-and-Trial Method

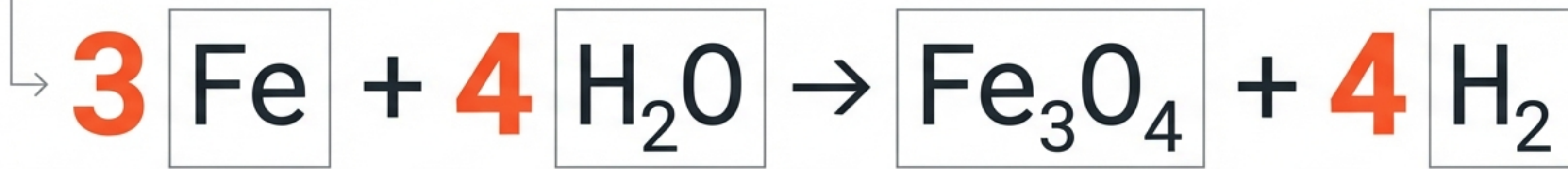
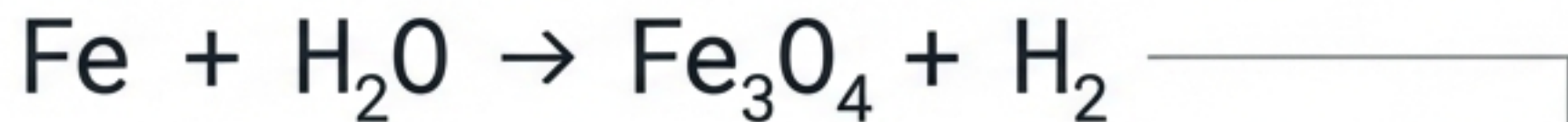

Iron (Fe)	LHS=3 RHS=3	✓
Hydrogen (H)	LHS=8 RHS=8	✓
Oxygen (O)	LHS=4 RHS=4	✓

Adding High Definition

Physical States and Conditions

(s) Solid, (l) Liquid, (g) Gas, (aq) Aqueous

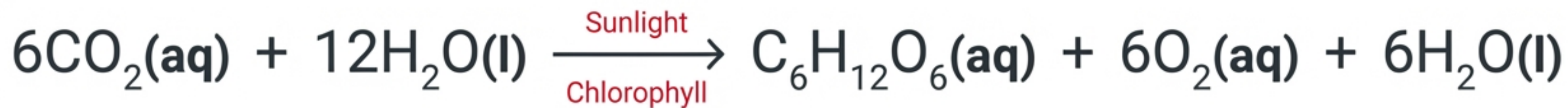

Conditions like temperature, pressure, and catalysts sit on the arrow—the stage directions for the reaction.

Type 2: Decomposition Reactions

Breaking Down ($A \rightarrow B + C$)

Thermal (Heat)



Ferrous Sulphate crystals lose water and decompose.

Electrolytic (Electricity)

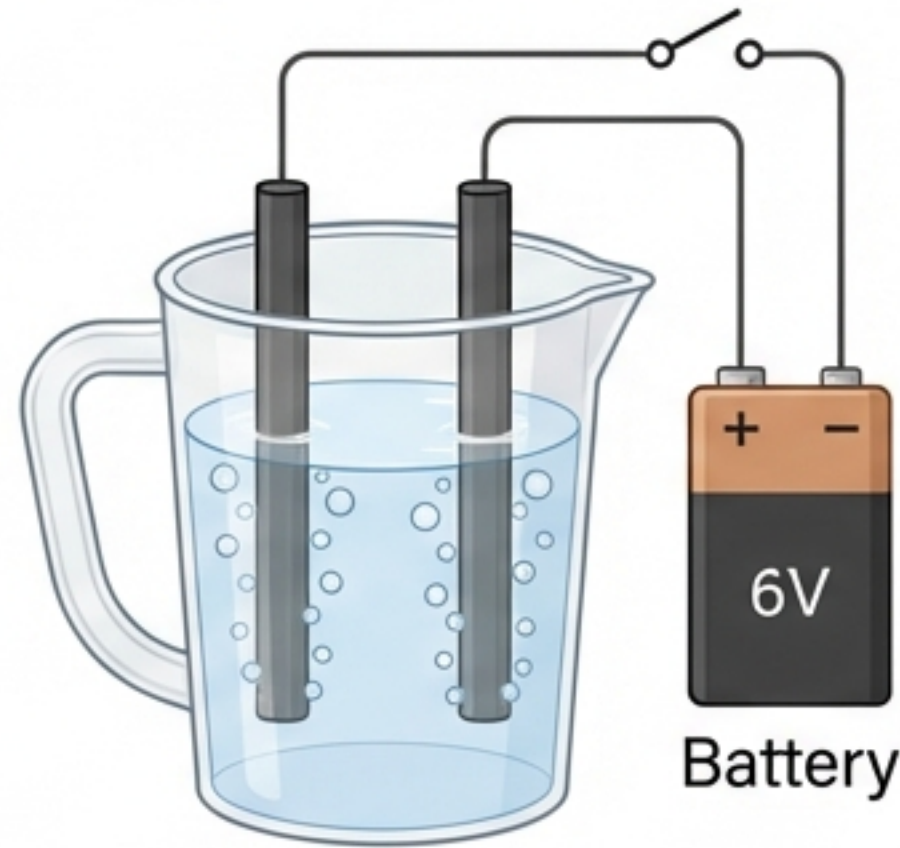

Electrolysis of Water

Photolytic (Light)



Silver Chloride in Sunlight

Endothermic Reactions: Energy is absorbed to break bonds.

Type 3: Displacement Reactions

The Power Swap ($A + BC \rightarrow AC + B$)

Before and After

Before

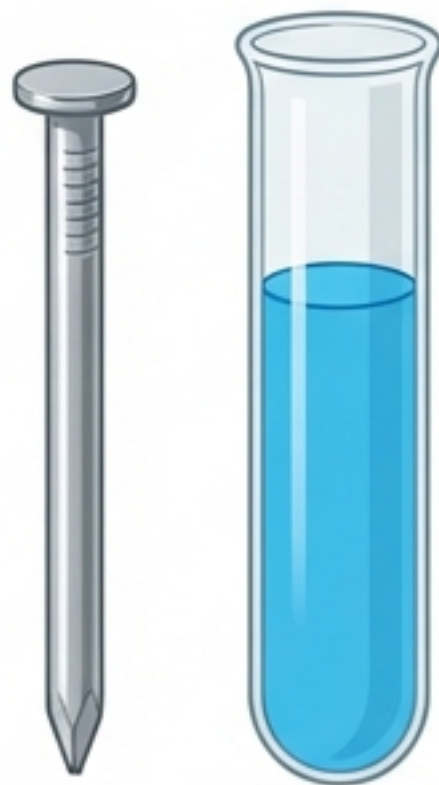

After

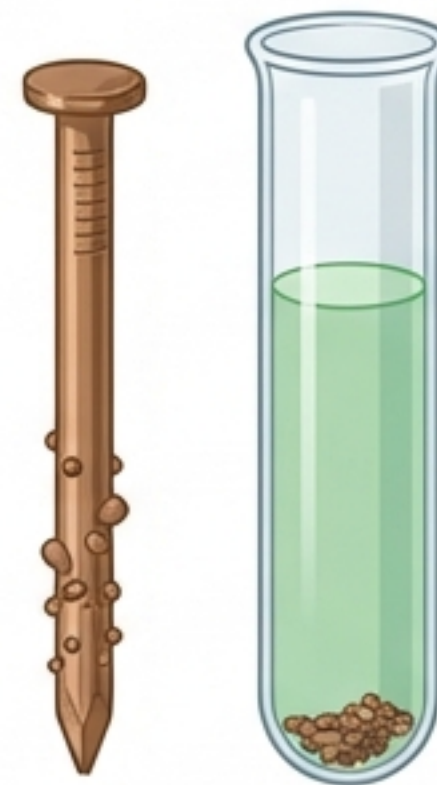

Iron is more reactive than Copper, displacing it from the solution.

Type 4: Double Displacement

Exchange of Partners ($AB + CD \rightarrow AD + CB$)

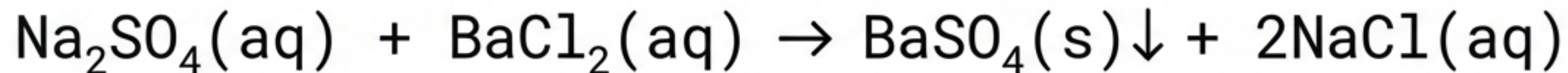
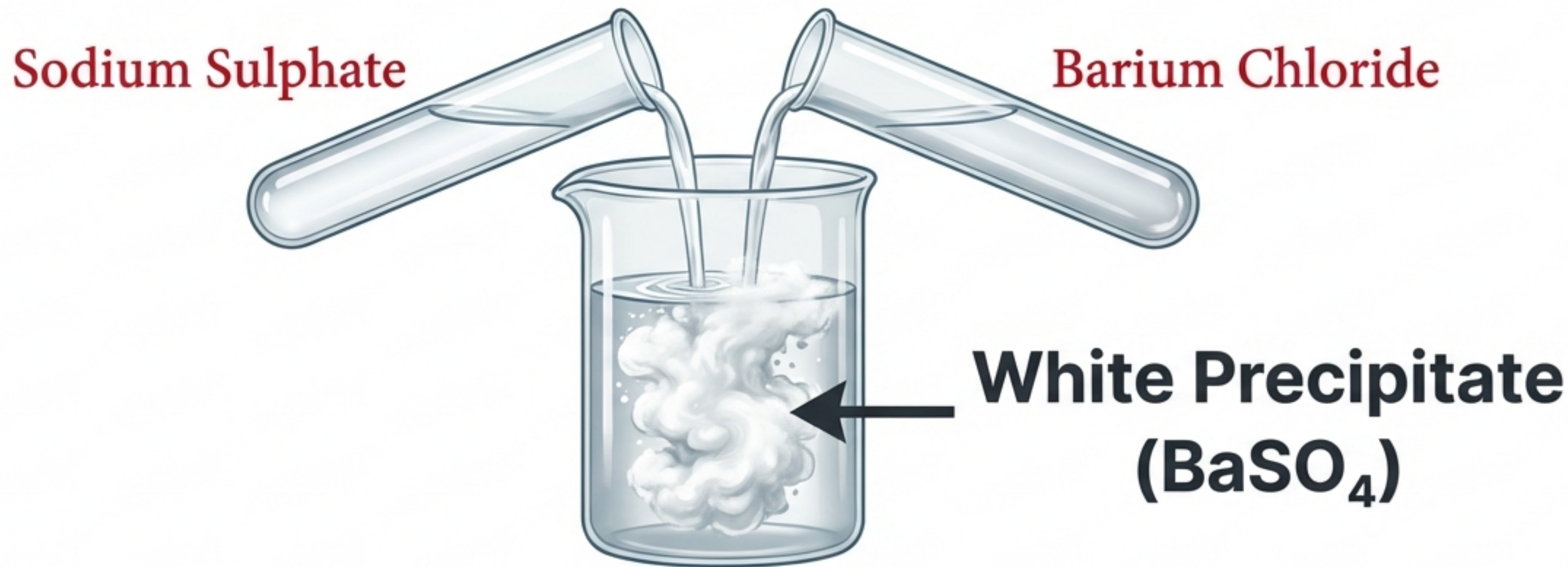

Precipitation Reaction: Any reaction that produces an insoluble solid.

Type 5: Oxidation and Reduction (Redox)

The Oxygen Exchange

Oxidation:
Gain of Oxygen /
Loss of Hydrogen

Reduction:
Loss of Oxygen /
Gain of Hydrogen

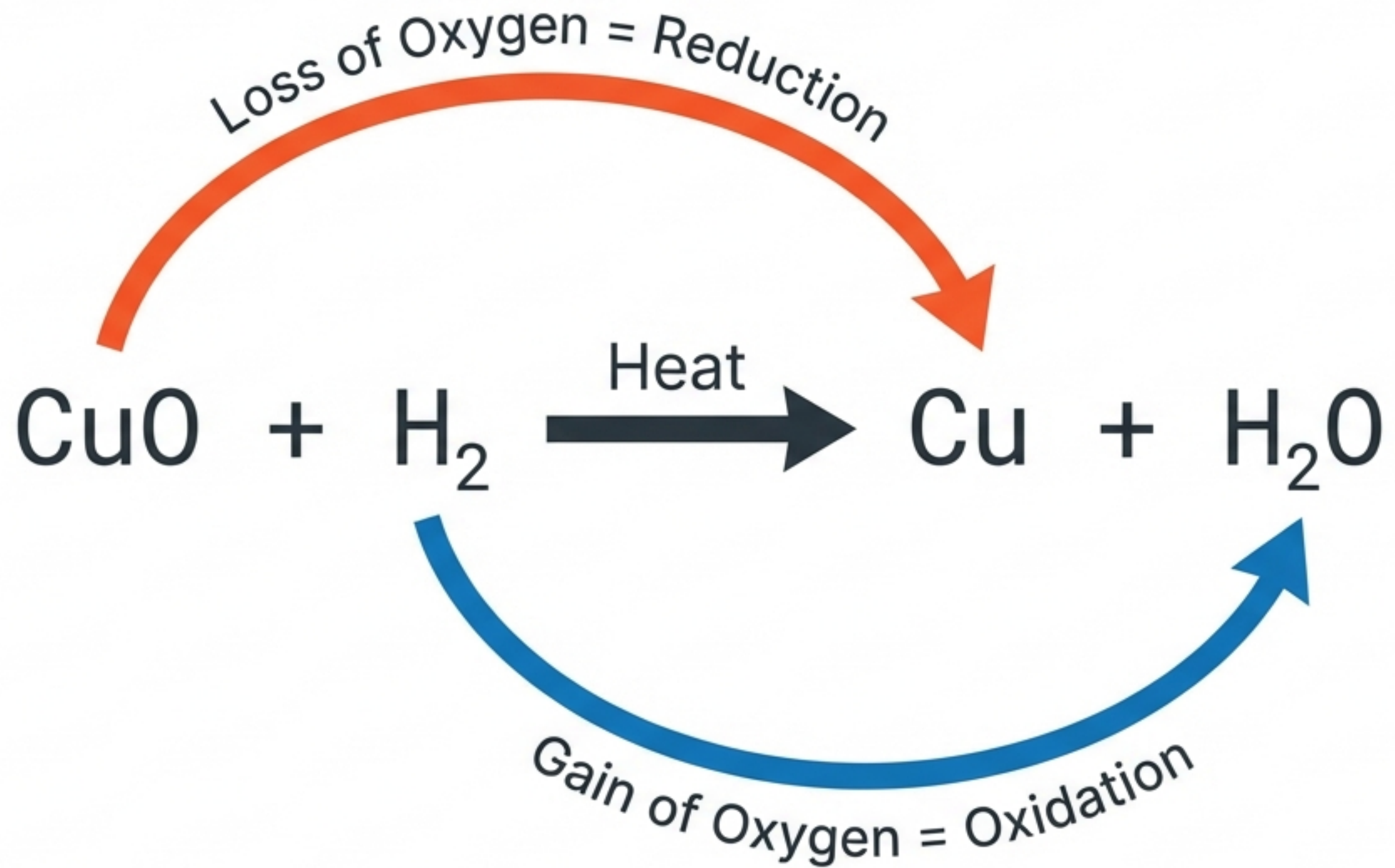

Oxidation in the Real World

Corrosion



Attack on metals by moisture and acids.

Rancidity

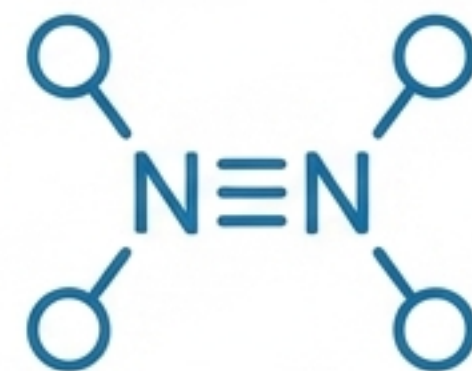

Oxidation of fats/oils causes bad smell/taste.
Prevented by flushing bags with Nitrogen.

Chemistry happens outside the lab.

The Language of the Universe

Reaction Type	General Equation	Key Concept
Combination	$A + B \rightarrow C$	Building
Decomposition	$A \rightarrow B + C$	Breaking
Displacement	$A + BC \rightarrow AC + B$	Swapping
Double Displacement	$AB + CD \rightarrow AD + CB$	Exchanging
Redox	Gain/Loss of Oxygen	Electron Shift

“Facts are not science — as the dictionary is not literature.” — Martin H. Fischer

The equations we balance are the sentences that describe our reality. Test your knowledge with the exercises in Chapter 1.